

# RT Series - HDPE Tight Head Container



Stackable, refillable container excellent for shipping and dispensing a wide range of **bulk liquid** products. Available in a wide range of sizes to facilitate a broad range of customer requirements.

- + Ideal for a wide range of industrial products including most corrosive chemicals or assorted liquid institutional food products.
- + **Returnable/refillable** feature provides economy and promotes environmental awareness.
- + No-Glug feature for ease of pouring available.
- + Recessed solid molded handle allows for non-aligned stacking and no liquid hold up in the handle area.
- + Standard 63mm & 70mm neck finish or optional crimp neck can accommodate a wide variety of dispensing devices.
- + Vented and non-vented available
- + Protective bumper area to accommodate sleeve.
- + Manufactured with high density polyethylene – food grade approved.
- + UN 3H1/Y1.8/100/YY  
USA/ +AA10353



SIL\_140 (8/2023)

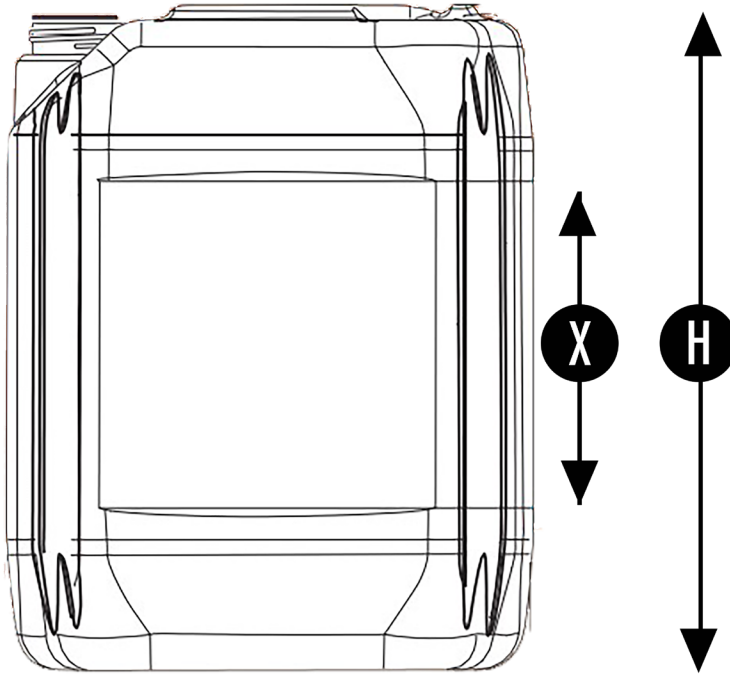
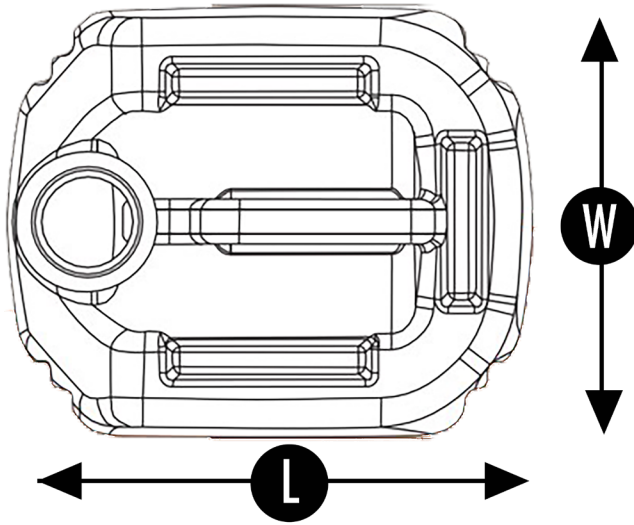

Capacity	20L	4G	5G
Weight	1200gm	970gm	1150gm
Height	381mm	307mm	366mm
Length	300mm	300mm	300mm
X	189mm	115mm	173mm

SIL\_140 (8/2023)